

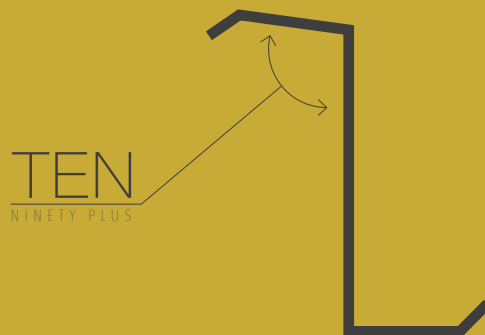

SWIF *TEN* RACKING SYSTEM
**STRUCTURAL CERTIFICATION LETTER
+ ENGINEERING DESIGN MANUAL**



SWIF Rack LLC

2850 Industrial Avenue

Hubbard, OR 97032

MAIN: (541) 490-0536

INFO@SWIFRACK.com

SUPPORT@SWIFRACK.com

SALES@SWIFRACK.com

SWIF *TEN* RACKING SYSTEM

TABLE OF CONTENTS

COVERSHEET.....	1
TABLE OF CONTENTS.....	2
ENGINEERING GUIDELINES.....	3
RAIL SECTION PROPERTIES.....	5
RAIL SINGLE SPAN.....	6
RAIL 3-SPAN.....	7
RAIL CANTILEVER.....	8
RAIL SPLICE	9
RAIL TO SWIF CAPACITIES.....	10
SWIF TO LIGHT GAUGE PURLIN.....	11
SWIF TO WOOD FRAMING.....	12
SWIF TO WOOD DECKING.....	13
SWIF TO CONCRETE DECKING.....	14

SWIF *TEN* RACKING SYSTEM ENGINEERING GUIDELINES

The tables contained in this manual provide allowable capacities. The project Engineer of Record is responsible for determining site specific design parameters. RAILS consist of zee purlins with a 10 degree tilt on the top flange. RAIL SPLICES are designed to occur anywhere along the RAIL line. The attachment of the RAIL to the SWIF is made with SELF DRILLING BOLTS. These provide flexural capacity in the direction perpendicular to the slope of the system to resist seismic racking forces. There are several SWIF base plate configurations available for different roof assemblies. Information on the attachment of the PV Modules to the RAILS is contained in the SWIF Rack SWIF *TEN* Racking System Installation Manual (hereafter referred to as the 'Installation Manual').

Recommended RAIL spacing in the figure below will ensure equal loading of the RAILS and SWIFS. Uniform RAIL loading will also depend on PV Module dimensions. Alternate RAIL spacing is acceptable but will result in uneven loading of the RAILS and SWIFS. The system designer is responsible for confirming the PV Module Manufacturer's Approved Clamping Areas, the extents within which the RAILS should be placed. The SWIFS may be staggered along the RAIL lines as needed to distribute loading evenly to the roof assembly.

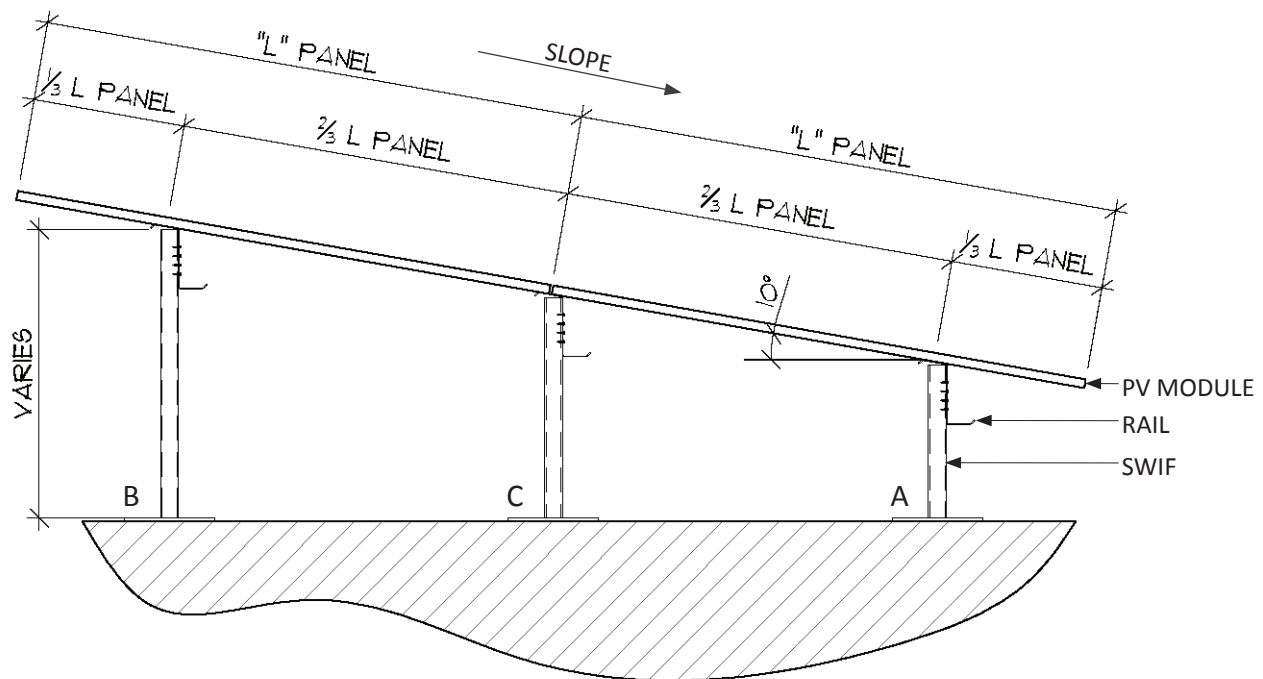

SWIF *TEN* RACKING SYSTEM ENGINEERING GUIDELINES

The design tables provided in this document are certified based on the structural performance of the SWIF *TEN* Racking System with no consideration of the structural adequacy of the underlying roof supporting members. It is the responsibility of the system designer to verify the structural capacity of the aforementioned system components in regards to the applied or resultant loads of any chosen array configuration.

Sincerely,



Jesse Wolfe, PE
Senior Structural Engineer



SWIF *TEN* RACKING SYSTEM

RAIL SECTION PROPERTIES

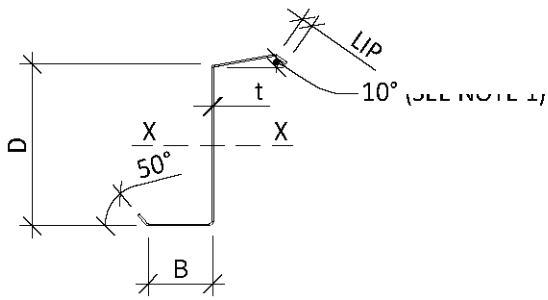

TYPICAL RAIL DIAGRAM

RAIL SECTION PROPERTIES							
RAIL PART NUMBER	D (in)	Gauge	t (in)	B (in)	Lip (in)	Ixx (in ⁴)	Area (in ²)
0616 / 0616SR	6	16	0.060	2.5	0.69	4.13	0.72
0614 / 0614SR	6	14	0.075	2.5	0.72	5.14	0.9
0814 / 0814SR	8	14	0.075	2.5	0.78	10.15	1.06
0812 / 0812SR	8	12	0.105	2.5	0.83	14.09	1.48
1014 / 1014SR	10	14	0.075	3	0.78	19.08	1.28
1012 / 1012 SR	10	12	0.105	4	0.83	31.69	2.01
1212 / 1212SR	12	12	0.105	4	0.99	48.39	2.22

SWIF *TEN* RACKING SYSTEM

RAIL SINGLE SPAN

RAIL SINGLE SPAN DESIGN TABLE							
Span (ft)	RAIL PART NUMBER						
	0616 / 0616SR	0614 / 0614SR	0814 / 0814SR	0812 / 0812SR	1014 / 1014SR	1012 / 1012 SR	1212 / 1212SR
4	1700	2400	2480	4300	1910	5200	4270
6	750	1030	1250	1850	1270	2850	2980
8	350	470	610	818	940	1580	1930
10	170	220	280	350	500	940	1200
12	80	105	130	170	250	580	730
14	n/a	n/a	70	93	140	360	440
16	n/a	n/a	n/a	n/a	80	221	265
18	n/a	n/a	n/a	n/a	n/a	134	164
20	n/a	n/a	n/a	n/a	n/a	90	105
22	n/a	n/a	n/a	n/a	n/a	n/a	70

NOTES

1. Loads are given as pounds per linear foot (PLF) and are unfactored.
2. RAIL weights may be added to the Load Table.
3. RAILS are designed to be unbraced.
4. Loads shown are stress governing.
5. Capacity is based on 55 KSI yield strength.

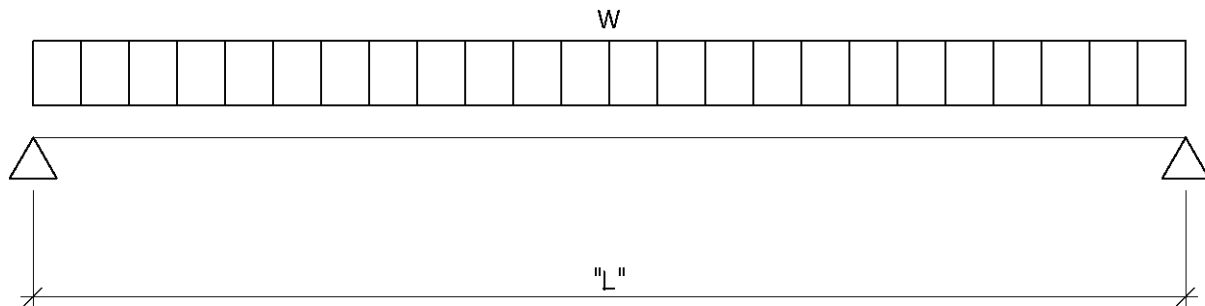

SWIF *TEN* RACKING SYSTEM

RAIL 3-SPAN

RAIL 3-SPAN DESIGN TABLE							
Span (ft)	RAIL PART NUMBER						
	0616 / 0616SR	0614 / 0614SR	0814 / 0814SR	0812 / 0812SR	1014 / 1014SR	1012 / 1012 SR	1212 / 1212SR
4	780	1076	1356	1356	1700	1700	2000
6	522	714	899	899	1100	1100	1350
8	392	539	677	677	671	850	1020
10	280	354	454	550	504	680	800
12	140	183	231	300	404	550	680
14	75	101	120	165	226	480	679
16	n/a	n/a	71	95	139	336	441
18	n/a	n/a	n/a	n/a	83	226	278
20	n/a	n/a	n/a	n/a	n/a	150	183
22	n/a	n/a	n/a	n/a	n/a	101	130

NOTES

1. Loads are given as pounds per linear foot (PLF) and are unfactored.
2. RAIL weights may be added to the Load Table.
3. RAILS are designed to be unbraced.
4. Loads shown are stress governing.
5. Capacity is based on 55 KSI yield strength.

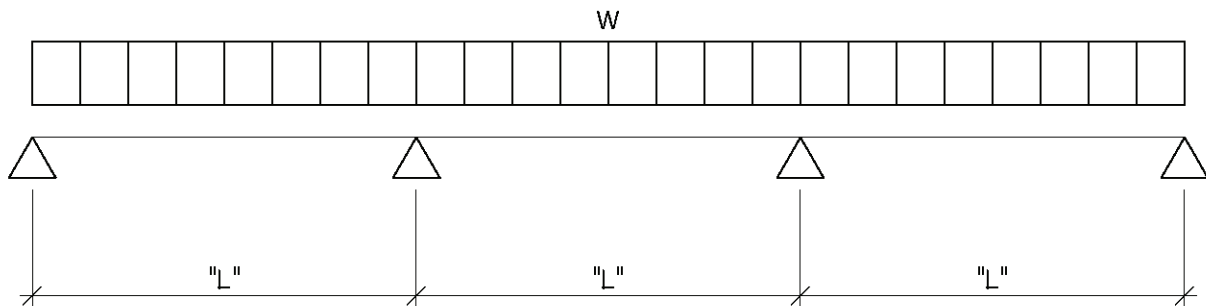

SWIF *TEN* RACKING SYSTEM RAIL CANTILEVER

RAIL CANTILEVER DESIGN TABLE							
Span (ft)	RAIL PART NUMBER						
	0616 / 0616SR	0614 / 0614SR	0814 / 0814SR	0812 / 0812SR	1014 / 1014SR	1012 / 1012 SR	1212 / 1212SR
4	334	430	598	750	729	1465	1564
6	70	90	118	140	224	542	680
8	n/a	n/a	n/a	n/a	67	182	223
10	n/a	n/a	n/a	n/a	n/a	70	86

NOTES

1. Loads are given as pounds per linear foot (PLF) and are unfactored.
2. RAIL weights may be added to the Load Table.
3. RAILS are designed to be unbraced.
4. Loads shown are stress governing.
5. Capacity is based on 55 KSI yield strength.

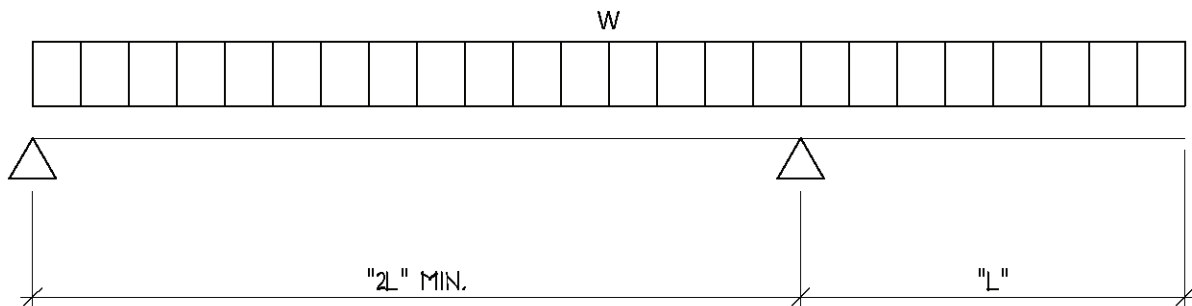

SWIF *TEN* RACKING SYSTEM RAIL SPLICE

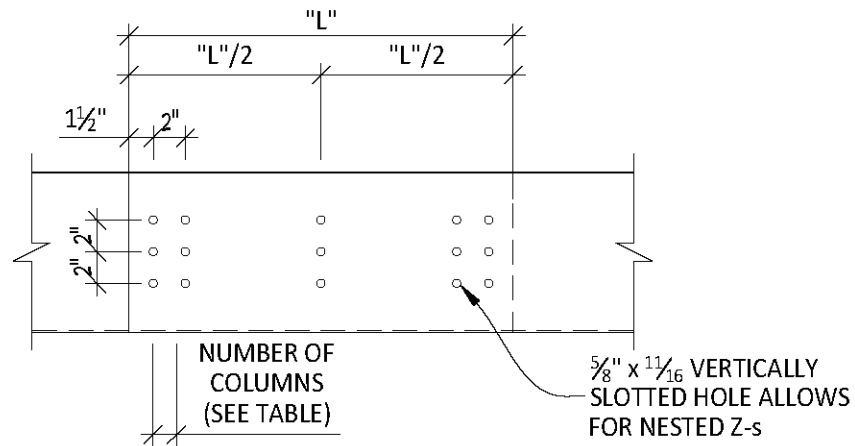

RAIL SPLICE CONFIGURATION			
RAIL PART NUMBER	ROWS OF FASTENERS	COLUMNS OF FASTENERS	RAIL SPLICE LENGTH
0616 / 0616SR	3	1	24
0614 / 0614SR	3	1	24
0814 / 0814SR	3	1	24
0812 / 0812SR	3	1	24
1014 / 1014SR	3	2	24
1012 / 1012 SR	3	2	24
1212 / 1212SR	3	2	24

NOTES

1. RAIL SPLICE can occur anywhere along length of RAIL.
2. Fasteners to be 1/2" diameter 316SS HEX BOLT ("SPLICE BOLT" SWIF PART # SB05).
3. RAIL SPLICE designed for full flexural and shear capacity of RAIL.
4. Middle row of fasteners may be omitted when splice occurs at support or mid-span.

SWIF *TEN* RACKING SYSTEM RAIL TO SWIF CAPACITIES

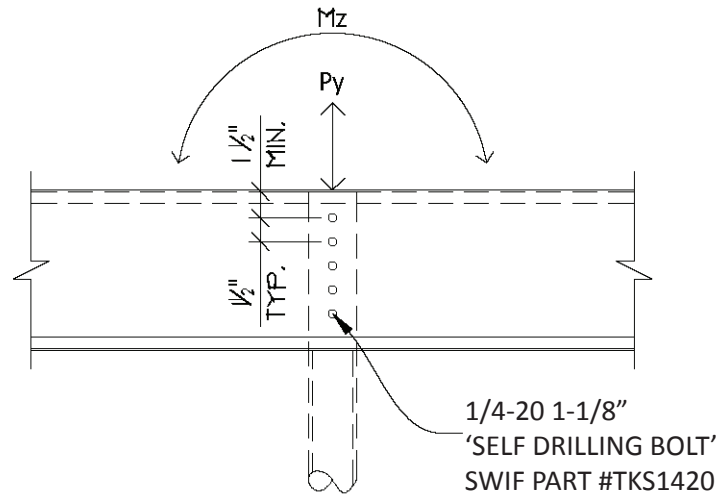

RAIL TO SWIF CONNECTION CAPACITY			
RAIL PART NUMBER	ROWS OF FASTENERS	Vn/Ω lbs	Mn/Ω lb-ft
0616 / 0616SR	3	2,445	204
0614 / 0614SR	3	2,445	204
0814 / 0814SR	4	3,260	408
0812 / 0812SR	4	3,260	408
1014 / 1014SR	5	4,075	611
1012 / 1012 SR	5	4,075	611
1212 / 1212SR	6	4,890	917

NOTES

1. Fasteners to meet the minimum requirements of ESR-2196.
2. Assumed that Seismic Racking and Maximum Gravity Load are not concurrent.

SWIF *TEN* RACKING SYSTEM SWIF TO LIGHT GAUGE PURLIN (LGP)

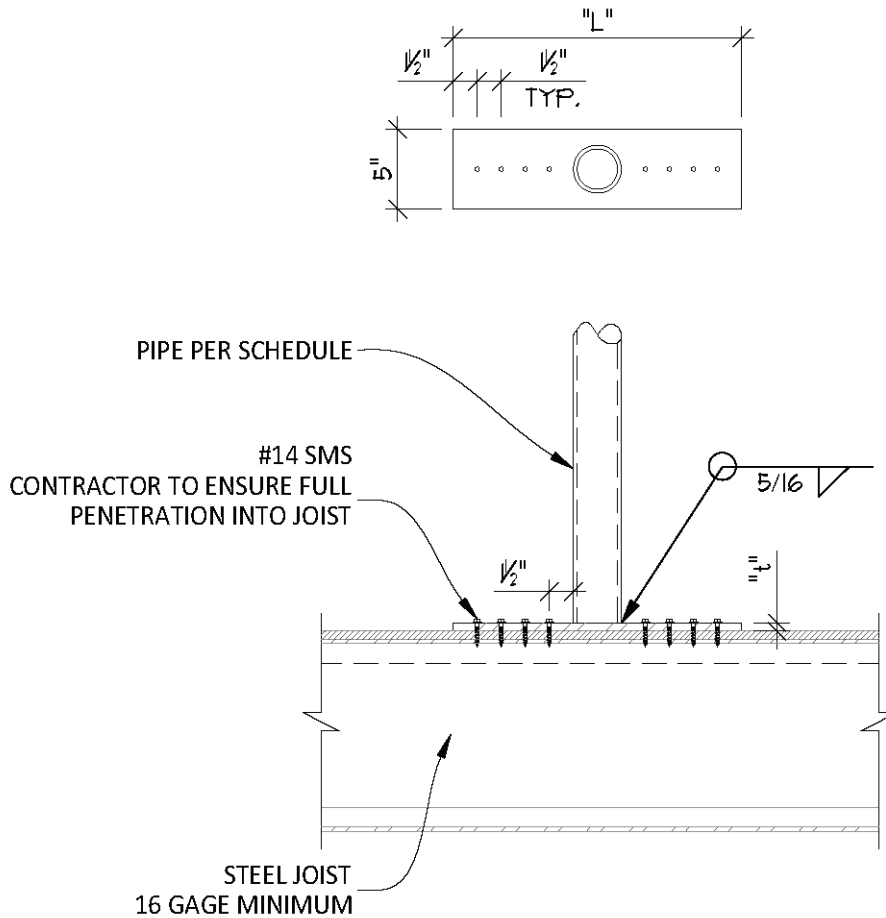

SWIF FOR LIGHT GAUGE PURLIN (LGP) ROOF STRUCTURE						
SWIF PART NUMBER	PIPE I.D.	"L" Plate in	"t" Plate in	N (screws) #	Mn/Ω k-in	Tn/Ω k
20_LGP_36/45/48/60	20 (2" Std.)	18	3/8	8	11.1	1.65
25_LGP_36/45/48/60	25 (2 1/2" Std.)	21	1/2	10	21.2	2.06
30_LGP_36/45/48/60	30 (3" Std.)	25	5/8	12	34.2	2.48
35_LGP_36/45/48/60	35 (3 1/2" Std.)	28	5/8	14	47.4	2.89

NOTES

1. Base Plate, Fy = 36 ksi.
2. Pipe, Fy = 35 ksi.
3. Designed for 1/4" Φ SMS into 16 gauge minimum Purlin.
4. Includes 1.44 Factor for Fu ≥ 65 ksi Purlin.
5. Values Based on ESR-2196.
6. SWIF Rack is not responsible for underlying supporting members.

SWIF *TEN* RACKING SYSTEM SWIF TO WOOD FRAMING (WF)

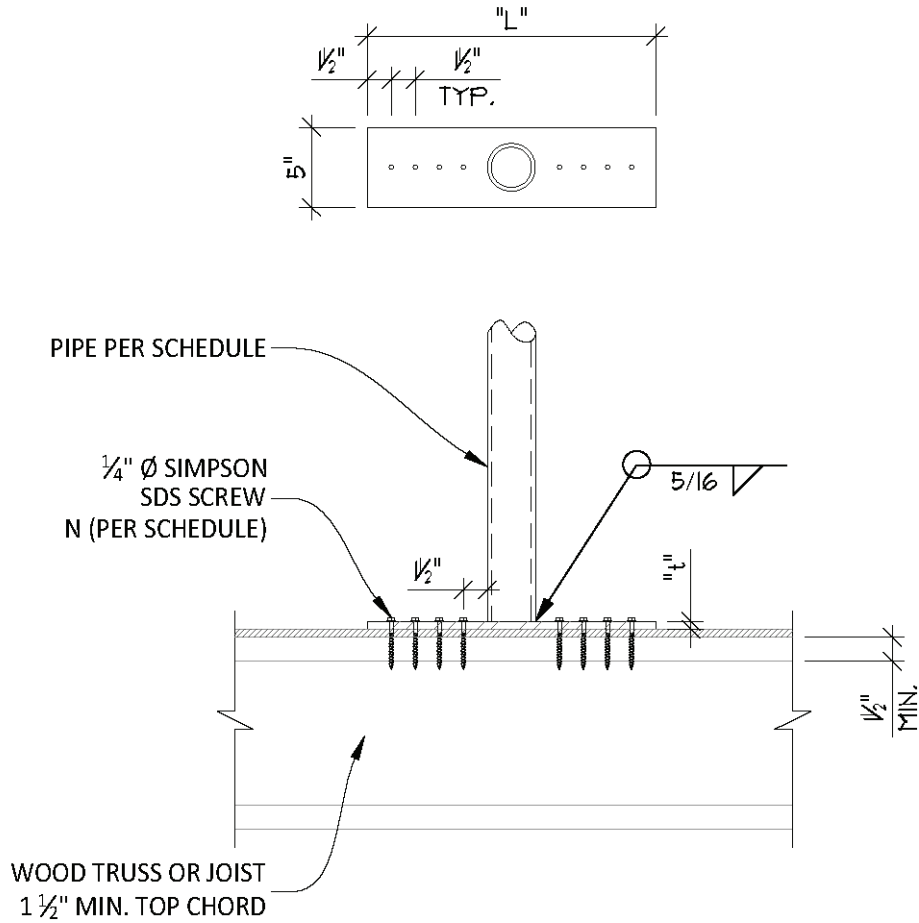

SWIF FOR WOOD FRAMING (WF) ROOF STRUCTURE

SWIF PART NUMBER	PIPE I.D.	"L" Plate in	"t" Plate in	N (screws) #	Mn/ Ω k-in	Tn/ Ω k
20_WF_36/45/48/60	20 (2" Std.)	15	3/8	6	11.1	1.24
25_WF_36/45/48/60	25 (2 1/2" Std.)	18	3/8	8	21.2	1.65
30_WF_36/45/48/60	30 (3" Std.)	22	1/2	10	34.2	2.06
35_WF_36/45/48/60	35 (3 1/2" Std.)	25	5/8	12	47.4	2.48

NOTES

1. Base Plate, $F_y = 36$ ksi.
2. Pipe, $F_y = 35$ ksi.
3. Designed for 1/4" Φ Simpson SDS screw with 1 1/2" minimum penetration into joist.
4. Includes $C_d = 1.6$ Load Duration.
5. Values Based on ESR-2236.
6. SWIF Rack is not responsible for underlying supporting members.

SWIF *TEN* RACKING SYSTEM SWIF TO WOOD DECKING (WD)

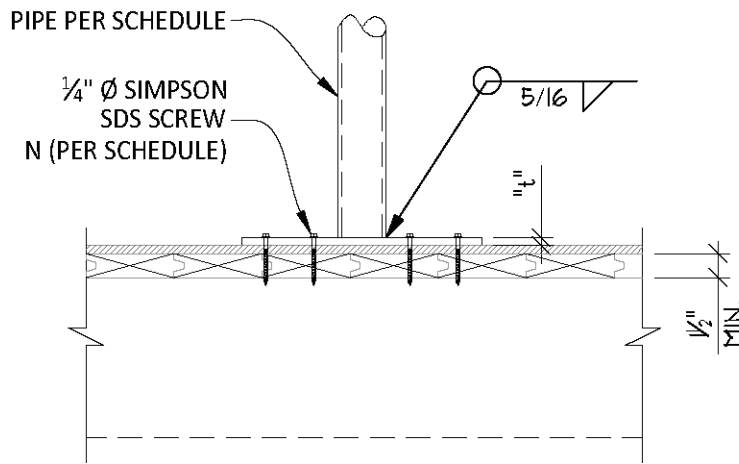
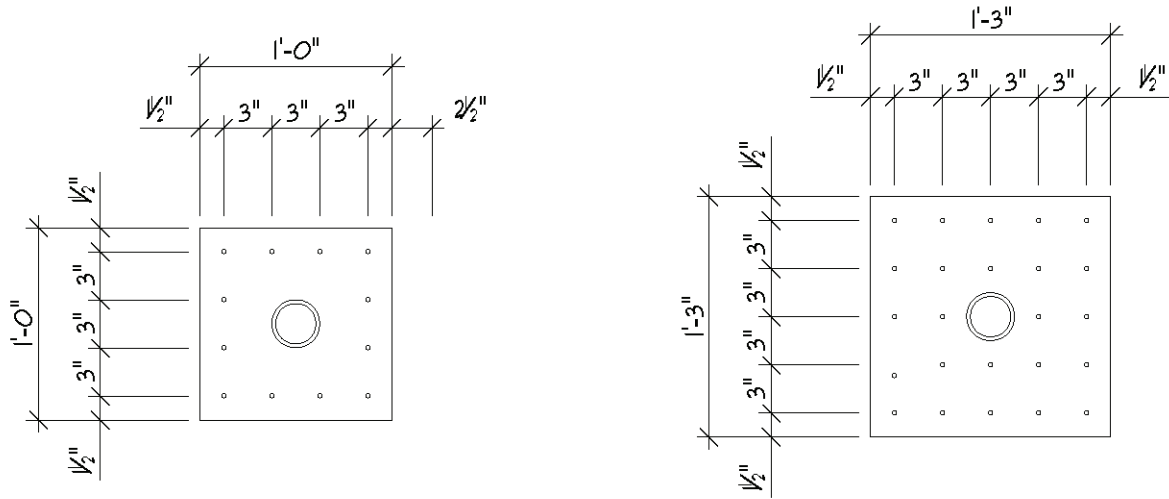

SWIF FOR WOOD DECKING (WD) ROOF STRUCTURE

SWIF PART NUMBER	PIPE I.D.	"L" Plate in	"t" Plate in	N (screws) #	Mn/Ω k-in	Tn/Ω k
20_WD_36/45/48/60	20 (2" Std.)	12	3/16	12	11.1	2.48
25_WD_36/45/48/60	25 (2 1/2" Std.)	12	3/16	12	21.2	2.48
30_WD_36/45/48/60	30 (3" Std.)	15	1/4	24	34.2	5.78
35_WD_36/45/48/60	35 (3 1/2" Std.)	15	1/4	24	47.4	5.78

NOTES

1. Base Plate, Fy = 36 ksi.
2. Pipe, Fy = 35 ksi.
3. Designed for 1/4" Φ Simpson SDS.
4. Includes Cd = 1.6 Load Duration.
5. Values Based on ESR-2236.
6. SWIF Rack is not responsible for underlying supporting members.

SWIF *TEN* RACKING SYSTEM SWIF TO CONCRETE DECKING (CD)

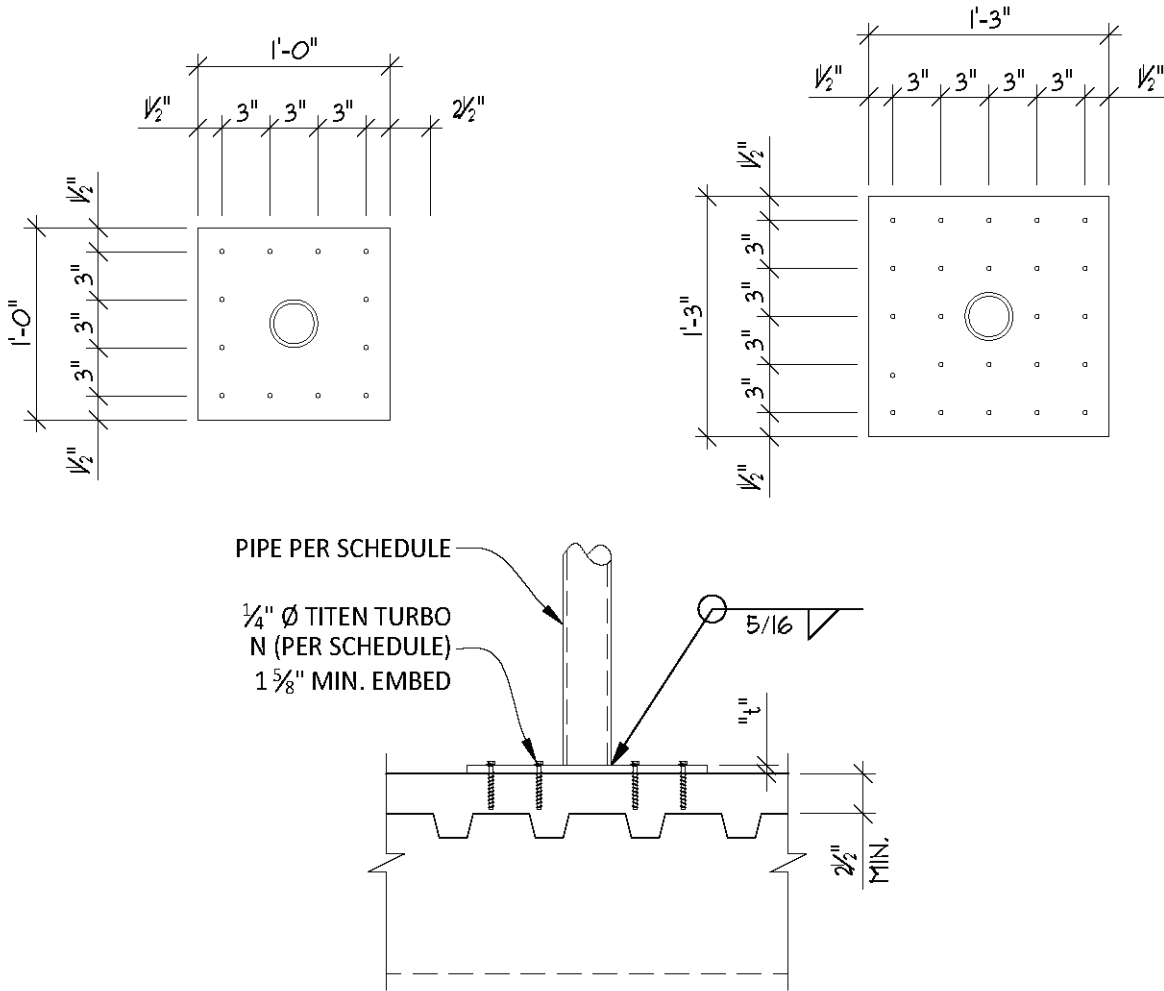

SWIF FOR CONCRETE DECKING (CD) ROOF STRUCTURE

SWIF PART NUMBER	PIPE I.D.	"L" Plate in	"t" Plate in	N (screws) #	Mn/Ω k-in	Tn/Ω k
20_CD_36/45/48/60	20 (2" Std.)	12	3/16	12	11.1	2.48
25_CD_36/45/48/60	25 (2 1/2" Std.)	12	3/16	12	21.2	2.48
30_CD_36/45/48/60	30 (3" Std.)	15	1/4	24	34.2	5.78
35_CD_36/45/48/60	35 (3 1/2" Std.)	15	1/4	24	47.4	5.78

NOTES

1. Base Plate, Fy = 36 ksi.
2. Pipe, Fy = 35 ksi.
3. Designed for 1/4" Φ Titen Turbo.
4. Values based on ESR-2713.
5. SWIF Rack is not responsible for underlying supporting members.