

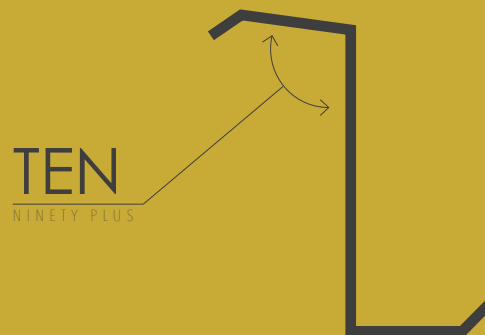

SWIF *TEN* RACKING SYSTEM INSTALLATION MANUAL



SWIF Rack LLC
2850 Industrial Avenue
Hubbard, OR 97032
MAIN: (541) 490-0536
INFO@SWIFRACK.com
SUPPORT@SWIFRACK.com
SALES@SWIFRACK.com

TABLE OF CONTENTS

RATINGS / CERTIFICATION DETAILS.....	2
INSTALLER RESPONSIBILITIES.....	3
COMPONENTS.....	4
PLAN YOUR SYSTEM - WHERE TO BEGIN.....	7
PLAN YOUR SYSTEM - CONFIGURATIONS.....	8
PLAN YOUR SYSTEM - SELECT COMPONENTS.....	9
COMPONENT SCHEDULES.....	10
PLAN YOUR INSTALLATION.....	11
INSTALLATION DETAILS.....	12
CLAMP LAYOUT.....	13
CLAMP INSTALLATION DETAILS.....	14
INSTALLATION SEQUENCE.....	16
BONDING CONNECTION GROUND PATHS.....	19
PANEL COMPATIBILITY.....	20
MARKINGS.....	21

RATINGS / CERTIFICATION DETAILS

SWIF RACK HAS BEEN EVALUATED BY INTERTEK TESTING SERVICES NA (ETL) AND LISTED TO UL STANDARD 2703 FOR BONDING & GROUNDING, MECHANICAL LOADING, AND FIRE CLASSIFICATION.

These requirements cover rack mounting systems, mounting grounding/bonding devices, and clamping/retention devices for specific (manufacturer/model designation) flat-plate photovoltaic modules and panels that comply with the Standard for Flat-Plate Photovoltaic Modules and Panels, UL 1703, or the Standard for Photovoltaic (PV) Module Safety Qualification – Part 1: Requirements For Construction, UL 61730-1 and the Standard for Photovoltaic (PV) Module Safety Qualification – Part 2: Requirements For Testing, UL 61730-2, intended for installation on or integral with buildings, or to be freestanding (i.e., not attached to buildings), in accordance with the National Electrical Code, ANSI/NFPA 70 and Model Building Codes.

Systems, components and/or devices evaluated under this standard may be used to ground and/or mount a PV module complying with UL 1703 or UL 61730-1 and UL 61730-2 when the specific module or frame has been evaluated for bonding/grounding or the module has been evaluated for mounting with the evaluated system, component or device.

These requirements cover rack mounting systems and clamping devices intended for use with photovoltaic module systems with a maximum system voltage of 1500 V. This racking system may be used to ground and/or mount a PV module complying with UL 1703 only when the specific module has been evaluated for grounding and/or mounting. Refer to the Panel Compatibility chart for a list of compatible modules.

These requirements cover rack mounting systems, clamping, retention devices pertaining to ground/bonding paths, mechanical strength, and suitability of materials only.

2703 FOR GROUNDING/BONDING

Conforms to UL 467 for Safety Grounding and Bonding Equipment

Max Over-current Protective Device (OCPD) Rating: 30A

Ground Conductor Rating: 6-10 AWG, bare copper. May require conduit protection for conductors smaller than 6 AWG according to NEC.

2703 FOR MECHANICAL LOADING

Maximum Panel Size: 27.4 sq. ft

Downward Design Load:	1600 Pa	Downward Test Load:	2400 Pa
Upward Design Load:	1600 Pa	Upward Test Load:	2400 Pa
Downslope Design Load:	5 psf	Downslope Test Load:	7.5 psf

Actual system structural capacity is defined by PE stamped certification letters.

CLASS A FIRE RATING PER UL 1703

Rated for Low Sloped Roof Application (less than 2 in/ft) when installed with Types 1, 2, 16, 29 or 30 UL 1703 Class PV Modules. Class A rated PV systems can be installed on Class A, B, and C roofs without affecting the roof fire rating. The end user must check the label for the fire type rating. A minimum of 24" roof gap under the panel is required.

INSTALLER RESPONSIBILITIES

It is recommended to review the complete manual prior to beginning installation.

THE FOLLOWING ARE THE SOLE RESPONSIBILITY OF THE INSTALLER:

- Comply with all applicable local, state or national building and fire codes, including any that may supersede the manual.
- Ensure that products used are appropriate for the particular installation, the environment and the PV array.
- Use only SWIF Rack products, products fabricated to SWIF Rack specifications as described in this manual, or products by other manufacturers as specified by SWIF Rack in this manual. Use of alternate products or fabrications may void any applicable warranty.
- Ensure that the roof, its rafters, connections, and other structural support members can support the PV array in its entirety.
- Maintain the waterproof integrity of the roof.
- Ensure correct and appropriate design parameters are used in determining the design loading used for the specific installation. Parameters, such as snow loading, wind speed, exposure and topographic factor should be confirmed with the local building official or a licensed professional engineer.
- Ensure bare copper grounding wire does not contact aluminum and zinc-plated steel components, to prevent risk of galvanic corrosion.
- Ensure safe installation of all electrical aspects of the PV array. All electrical installation and procedures should be conducted by a licensed and bonded electrician or solar contractor.
- Ensure all warning label requirements are met per the latest National Electrical code (NEC), International Fire Code (IFC), and/or Cal Fire Code.
- Provide an appropriate method of direct-to-earth grounding according to the latest edition of the National Electrical code including NEC 250: Grounding and Bonding, and NEC 690: Solar Photovoltaic Systems.
- Do not during routine maintenance, inspection, or cleaning, break or disturb the bonding path of the system.
- If loose components or fasteners are identified during periodic inspection, re-tightened or replace immediately as specified by the component manufacturer. If corrosion is found, replace the affected components immediately.
- This rack system may be used to roof mount and ground PV panels complying with UL 1703 only when the specific panel has been evaluated for grounding and/or mounting with the SWIF Rack rack system as described in this manual. See the PV panel Compatibility section.
- Ensure the provided information is accurate. Issues resulting from inaccurate information are the installer's responsibility.
- Review PV panel manufacturer's documentation for compatibility and compliance with warranty terms and conditions.

COMPONENTS

RAILS

1. Spans between SWIFS and supports PV PANELS.
2. 100° bend places top flange flush to PV PANEL frames when sloped at 10°.
3. Pre-punched holes on top flange of SHARED RAIL for faster MID CLAMP ASSEMBLY installation.
4. Weep holes on bottom flange reduce water accumulation.
5. Bottom flange can be used for cable management.
6. G90 galvanized coating resists corrosion conforming with ASTM A653.

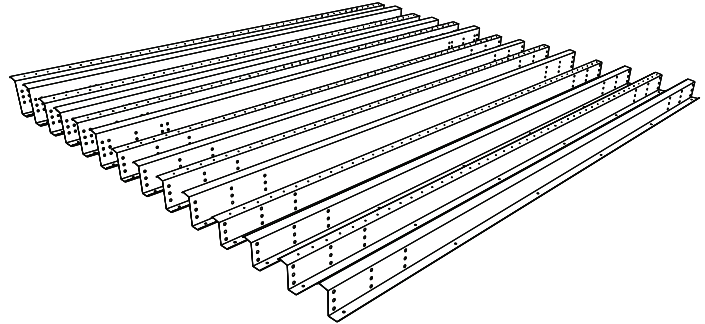

RAIL SPLICE

1. Aligns contiguous RAILS and electrically bonds RAILS together.
2. Secured with SPLICE BOLTS.

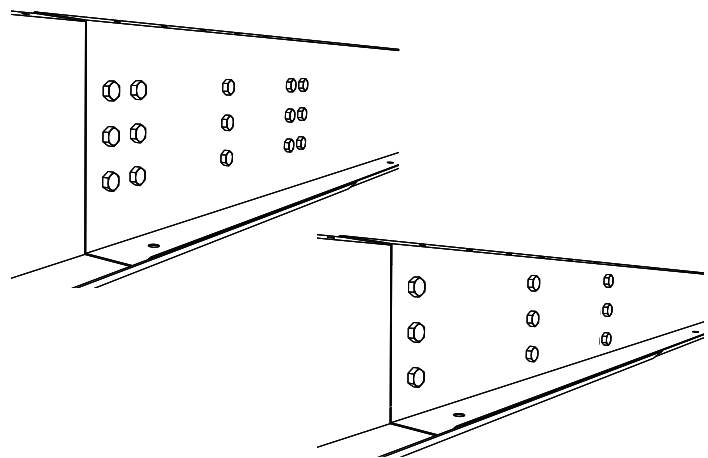

SWIF

1. Elevates RAILS for full roof access under the PV PANELS.
2. Integrated steel baseplate FOOT for a positive connection to the building roof structure.
3. G90 galvanized coating conforming to ASTM A123 resists corrosion.
4. Customized LEG + FOOT combinations for different building structures and loading conditions.
5. Option to fabricate custom FOOT configurations for unique structural conditions.

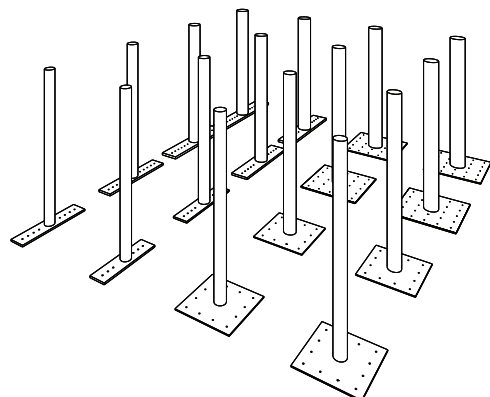

COMPONENTS

MID CLAMP ASSEMBLY

CONDUCTIVE MID CLAMP* (MID CLAMP)

1. 316 Stainless Steel
2. Penetrates solar frame anodization with sharp teeth for strong electrical conductivity.
3. Mechanically holds solar panels in place, providing structural support.
4. Features spacing flaps for panel alignment.

CARRIAGE BOLT & NUT

1. 316 Stainless Steel.
2. Provides bonding between CONDUCTIVE MID CLAMPS and the RAILS.
3. CARRIAGE BOLT locks together with MID CLAMP to resist turning, allows for single side tightening.

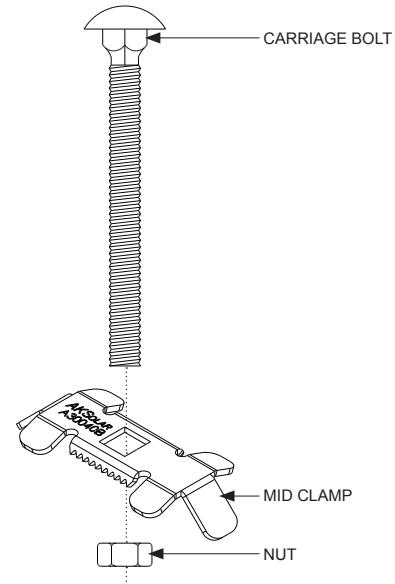

END CLAMP ASSEMBLY

CONDUCTIVE END CLAMP* (END CLAMP)

1. 316 Stainless Steel.
2. Penetrates solar frame anodization with sharp teeth for strong electrical conductivity.
3. Mechanically holds solar panels in place, providing structural support.

HEX BOLT WITH WASHER & NUT

1. 316 Stainless Steel
2. Provides bonding between CONDUCTIVE END CLAMPS and the RAILS.

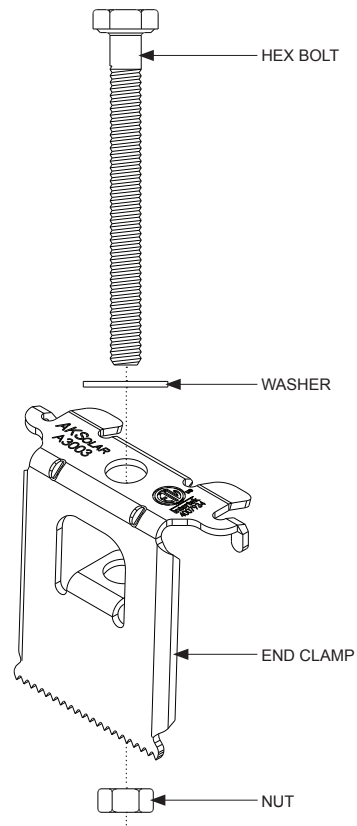

* For single use only.

COMPONENTS

SELF DRILLING BOLT*

1. Attaches SWIFS to RAILS.
2. Electrically bonds SWIFS and RAILS together.

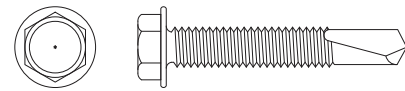

SPLICE BOLT

1. 316 Stainless Steel.
2. Secures RAIL SPLICE.
3. Electrically Bonds RAILS together.

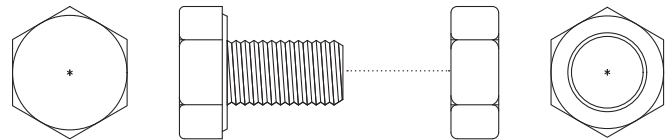

GROUNDING CONNECTION WITH MOUNTING HARDWARE

Amphenol HG Helios Grounding Products
HelioLug (wire range 4-12 AWG)

1. UL2703 for use with a ground wire.
2. Meets all NEC 2008/2011 requirements.
3. Capable of accepting 4-12 AWG solid copper conductors.
4. Comes with all certified custom hardware needed for making rapid, secure connections to PV modules and racks.

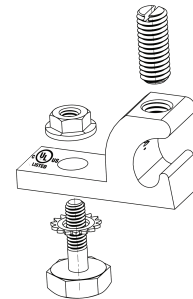

SWIF CAP

1. Caps the top of the SWIF LEG.
2. O-ring prevents water intrusion.
3. Ideal for multiphase installation.

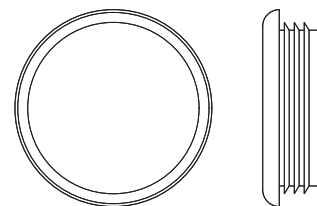

* For single use only.

PLAN YOUR SYSTEM - WHERE TO BEGIN

CONSULT A LICENSED PROFESSIONAL ENGINEER as necessary throughout the design, permitting and installation process to ensure Building Structural Capacity per the applicable codes and standards and for assistance in selecting and configuring the appropriate SWIF *TEN* Racking Components for your system Arrays. SWIF *TEN* Racking can be customized to suite many different building structure types and building plans. The SWIF *TEN* Racking System STRUCTURAL CERTIFICATION LETTER + ENGINEERING DESIGN MANUAL (DESIGN MANUAL) provides information on allowable capacities to assist with racking component selection. Array configurations must comply with the parameters set forth in this INSTALLATION MANUAL as well as any local, state or national building and fire codes, including any that may supersede this manual. Final racking configuration and layouts are the responsibility of the Project Engineer of Record.

GATHER INFORMATION

1. Gather information on the Building Roof Structure Type and the Roof Structural Plan.

RESOURCES

1. SWIF *TEN* Racking INSTALLATION MANUAL
2. SWIF *TEN* Racking System STRUCTURAL CERTIFICATION LETTER + ENGINEERING DESIGN MANUAL (DESIGN MANUAL)

Other Resources

1. SWIF *TEN* Racking COMPONENT DATA SHEETS
2. SWIF *TEN* Racking ORDER FORM

Visit www.SWIFRack.com/downloads to access these and other design resources. Contact SWIF Rack with questions or support requests. Contact information can be found at www.SWIFRack.com/ContactUs.

SELECT A PV MODULE

1. Select an approved PV Module from the SWIF *TEN* Racking APPROVED PV MODULES LIST, download from the website.
2. Review the PV Module Manufacturer's Installation Manual.

PV Module options continue to grow and improve every day. Call SWIF Rack at (541) 490-0536 or email us at www.SWIFRACK.com/ContactUs if the PV Module you want to use for your project is not included in this list yet, if the clamp mounting configuration you require hasn't been evaluated by the PV Module Manufacturer yet or if the PV Module is not yet evaluated for a Fire Rating. SWIF Rack will evaluate the panel for use with our system and work with the Module Manufacturer and an UL evaluating entity to certify the PV Module with the SWIF *TEN* Racking System.

PLAN YOUR SYSTEM - CONFIGURATIONS

TWO CUSTOMIZABLE CONFIGURATIONS

SINGLE PANEL ARRAY

- (2) RAILS support a single row of panels.

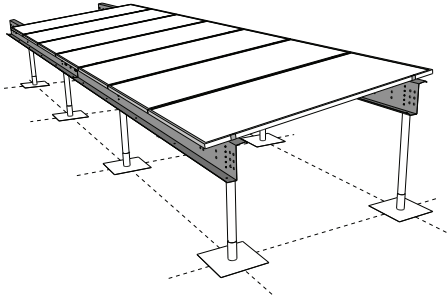

PLAN

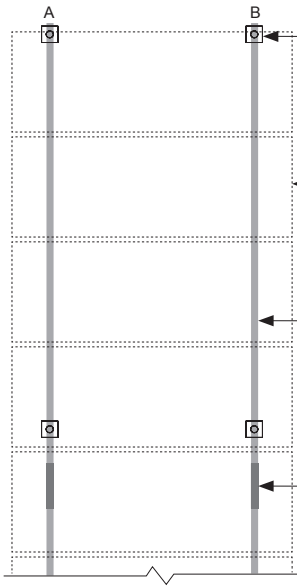

ELEVATION

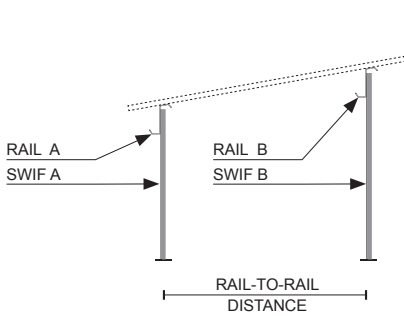

TWO PANEL SHARED RAIL ARRAY

- (3) RAILS support two rows of panels.
- The panels share the middle rail for support.

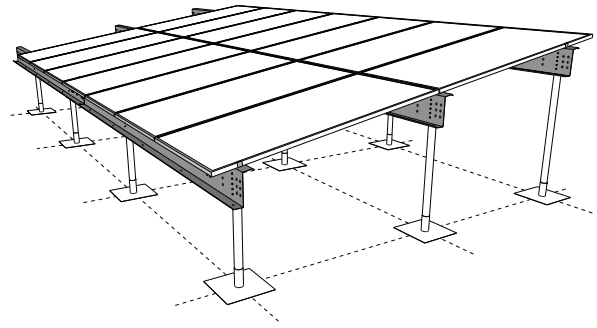

PLAN

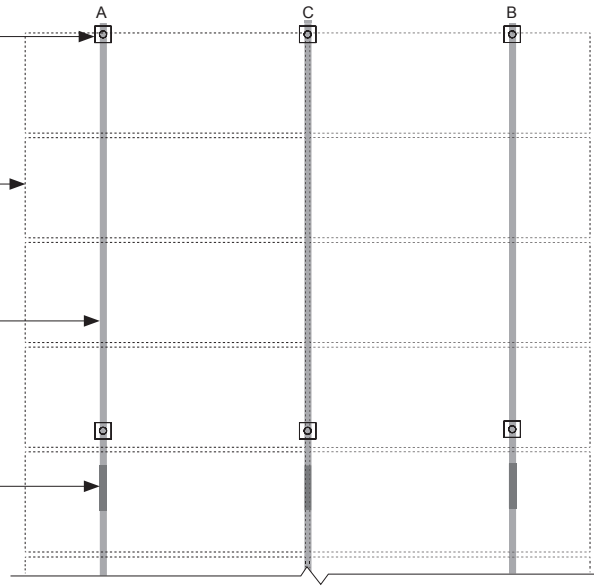

ELEVATION

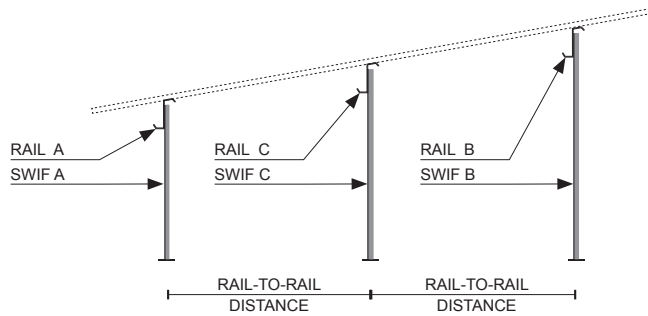

PLAN YOUR SYSTEM - SELECT COMPONENTS

1. ESTABLISH RAIL-TO-RAIL DISTANCE

Establish the RAIL-to-RAIL distance between RAILS A & B or between RAILS A, C & B.

- Distances between the RAILS are determined by where the CLAMPS can be applied to the PV Module as specified by the PV Module Manufacturer in the PV Module Installation Manual.

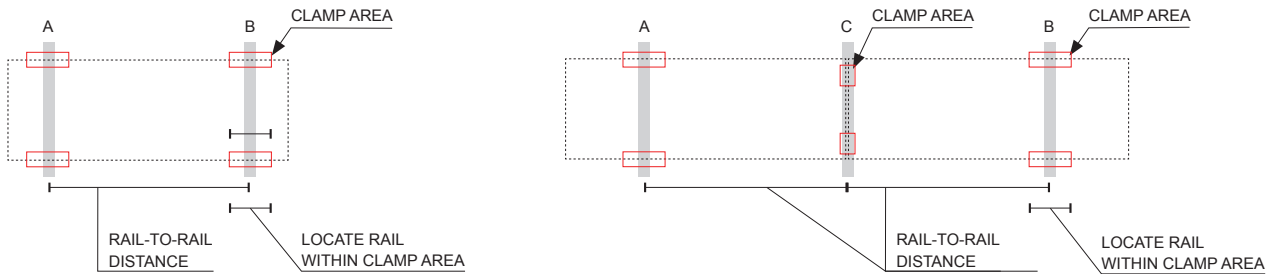

2. DETERMINE THE TOTAL LENGTH OF EACH PV ARRAY

Add 3/8" between each PV Module to account for the width of the clamp assemblies.

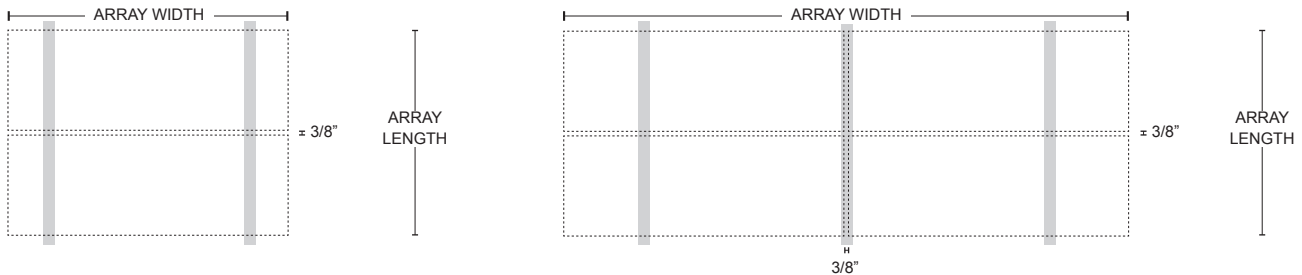

3. SELECT SWIFS

Locate support points along the line of each RAIL and select the appropriate SWIF LEG + FOOT combination for each RAIL.

- Refer to the COMPONENT SCHEDULE on page 10 for a list of available SWIF sizes and configurations.
- Refer to the SWIF TEN Racking System STRUCTURAL CERTIFICATION LETTER + ENGINEERING DESIGN MANUAL pages 11-14 for information on SWIF capacities.

4. SELECT RAILS

Select the size of RAILS A & B or RAILS A, C & B for the Array.

- Refer to the COMPONENT SCHEDULE on page 10 for a list of available RAIL sizes.
- Refer to the SWIF TEN Racking System STRUCTURAL CERTIFICATION LETTER + ENGINEERING DESIGN MANUAL pages 5-8 for information on RAIL capacities.

5. IDENTIFY RAIL SPLICES

RAIL SPLICES are necessary when the total length of a RAIL in an Array exceeds the maximum length of a RAIL Component. The RAIL will be divided into a minimum number of equal length RAIL Components. The length of each RAIL Component will be increased to accommodate the necessary overlap required for the RAIL SPLICE.

- Refer to the SWIF TEN Racking System STRUCTURAL CERTIFICATION LETTER + ENGINEERING DESIGN MANUAL page 9 for information on RAIL SPLICES.

PLAN YOUR INSTALLATION

REVIEW

Begin by reviewing the SWIF *TEN* Racking INSTALLATION MANUAL, including the INSTALLER RESPONSIBILITIES section on page 3, the complete SWIF *TEN* Racking System STRUCTURAL CERTIFICATION LETTER + ENGINEERING DESIGN MANUAL and the approved Permit documents for your project.

RECOMMENDED TOOLS

1. Tape Measure
2. Magnetic Level
3. String Line
4. Speed Square
5. Box Level, 5' Minimum
6. Rubber Mallet
7. Heavy Duty Pipe Cutter, up to 4" Diameter Capacity
8. Pipe Pliers with V-Pads, up to 5" Capacity
9. Locking C-Clamp, up to 5" Capacity
10. Drill & Impact Driver
11. 7/32" and 5/16" Metal Drill Bits
12. Socket Set
13. Torque Wrench
14. Cold Galvanized Spray / Cold Galvanized Paint - 97% zinc rich, blended with an epoxy resin

TORQUE SPECIFICATIONS

MID CLAMP ASSEMBLY	10 FT-LBS
END CLAMP ASSEMBLY	10 FT-LBS
SELF DRILLING BOLT	10 FT-LBS Can be installed using a standard screw gun with a minimum of 6 amps, and having a RPM range of 1800 to 2500 RPM.
SPLICE BOLT	10 FT-LBS
GROUND LUG	To attach to the racking, mount on a flat surface if used in a channel, or into a ¼" hole drilled through the extrusion. Place the star washer between the racking and lug and secure the nut and bolt to 30 IN-LBS . Insert a 4 to 12 AWG copper wire into the lug and tighten the lug set screw to the copper wire to the torque based on the wire size. 4-6 AWG at 35 IN-LBS 8-12 AWG at 30 IN-LBS

Do not exceed the maximum rated overcurrent protection, 20 A (12 AWG), 40 A (10 AWG), 90 A (8 AWG), 150 A (6 AWG), and 200 A (4 AWG).

INSTALLATION DETAILS

Refer to the SWIF *TEN* Racking System STRUCTURAL CERTIFICATION LETTER + ENGINEERING DESIGN MANUAL (DESIGN MANUAL) for a full description of these connection details.

SWIF TO ROOF CONNECTION

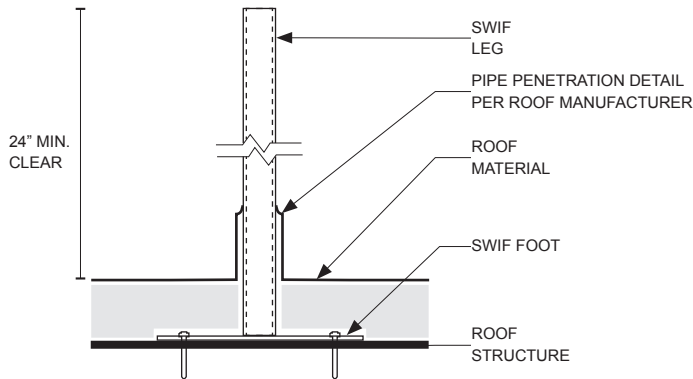

- Pipe penetration details per roof manufacturer approved specifications is required.
- Maintain 24" minimum clear area between top of finished roof and top of SWIFS.
- See DESIGN MANUAL pages 11-14.

RAIL TO SWIF CONNECTION

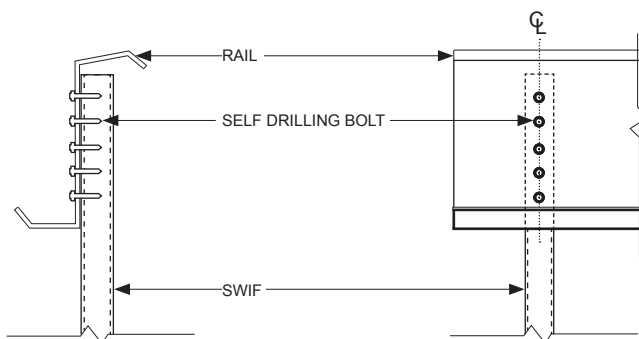

- Align SELF DRILLING BOLTS with the SWIF leg.
- SWIFS may be shortened in the field to allow for leveling the RAILS.
- See DESIGN MANUAL page 10.

RAIL SPLICE

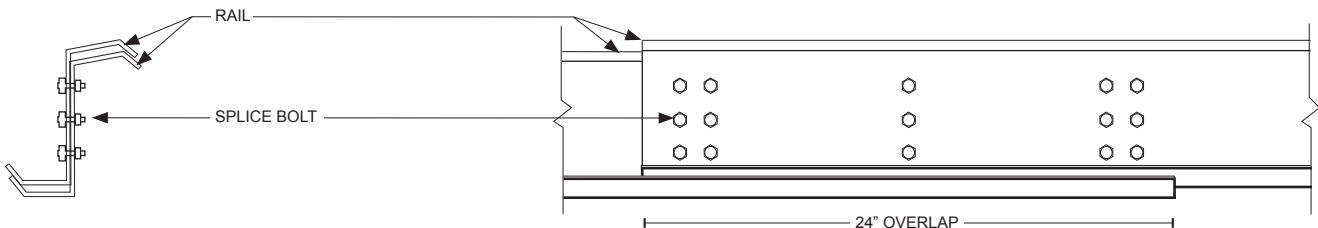

- RAIL SPLICE overlap is exaggerated for graphic clarity. Due to flex in the material, RAILS are effectively flush apart from their material thickness at the RAIL SPLICE.
- Fully align pre-punched RAIL SPLICE pattern to achieve 24" overlap.
- See DESIGN MANUAL page 9.

CLAMP LAYOUT

KEY

CLAMP ASSEMBLY TYPE	
END CLAMP ASSEMBLY	■
MID CLAMP ASSEMBLY	●

SINGLE PANEL ARRAY

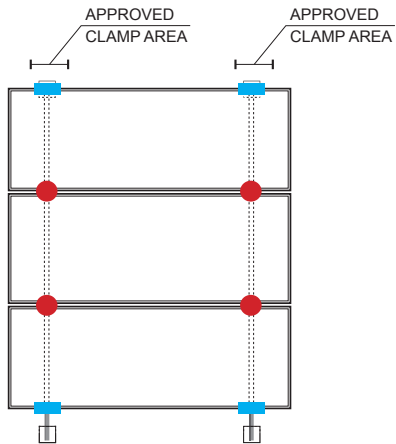

TWO PANEL SHARED RAIL ARRAY

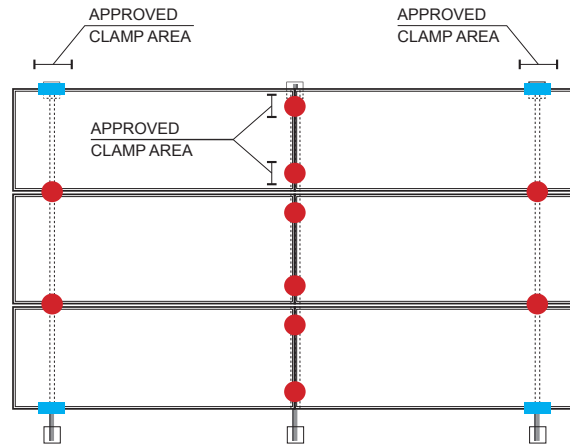

NOTES

1. APPROVED CLAMP AREA: MID CLAMP and END CLAMP placement are determined by the PV Module Manufacturer. See page 9, 'ESTABLISH RAIL-TO-RAIL DISTANCE.'
2. Install MID CLAMPS between PV PANELS within a PV PANEL ARRAY. See page 14.
3. Install END CLAMPS at each end of a PV PANEL ARRAY. See page 15.

CLAMP INSTALLATION DETAILS

MID CLAMP ASSEMBLY

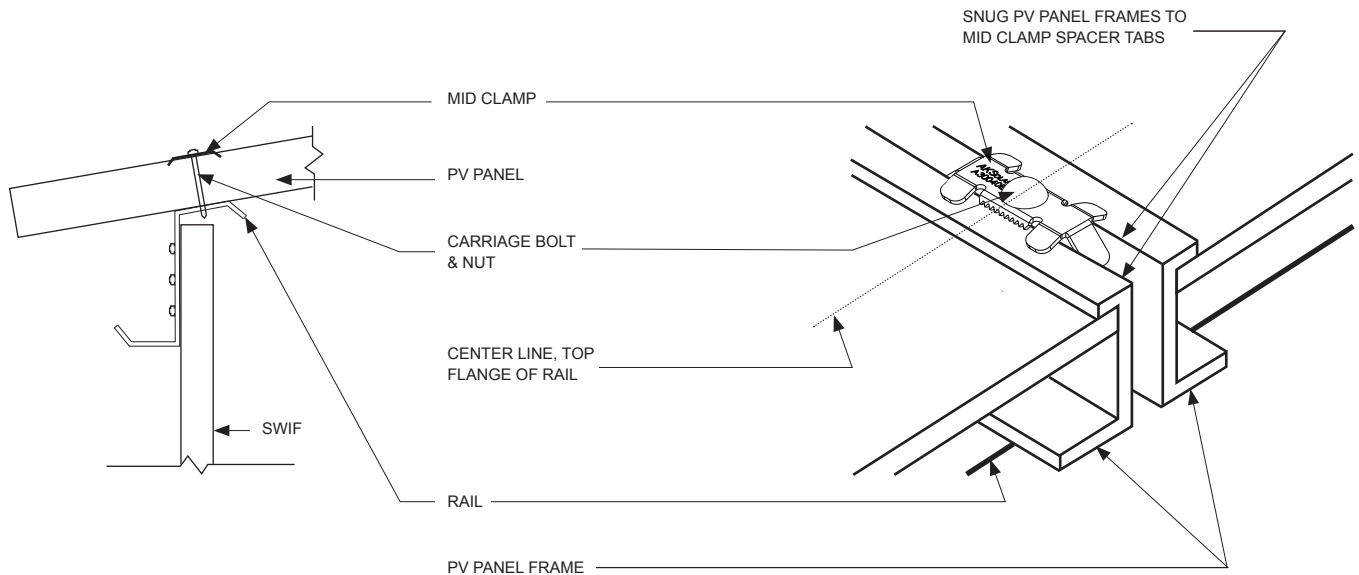
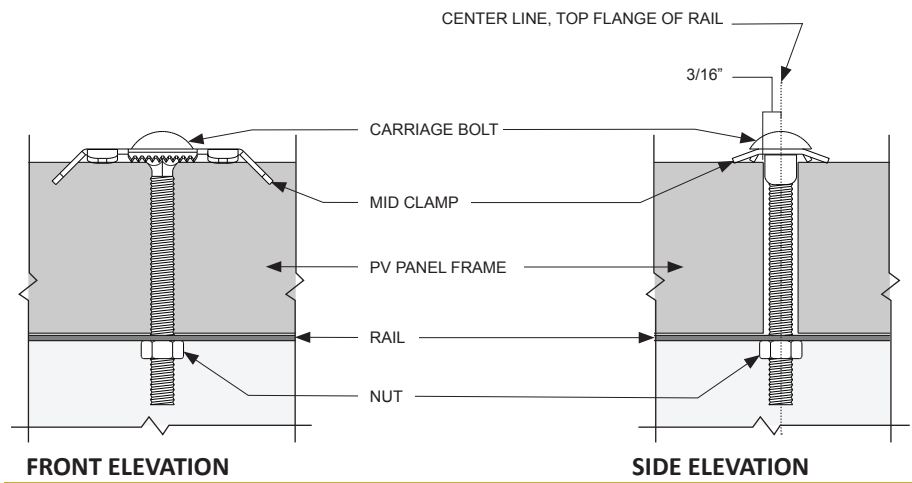
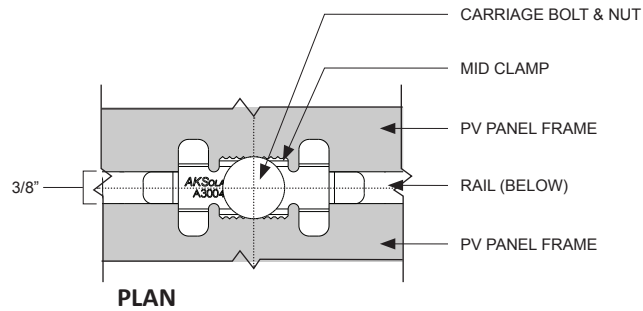
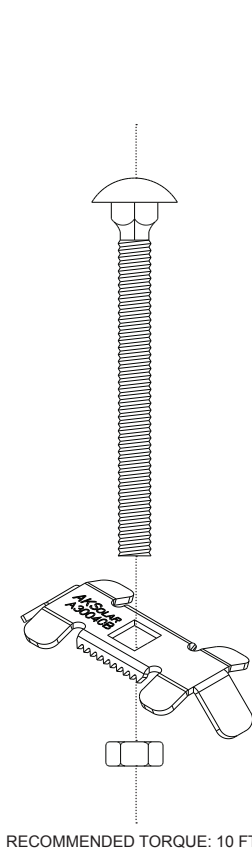

CLAMP INSTALLATION DETAILS

END CLAMP ASSEMBLY

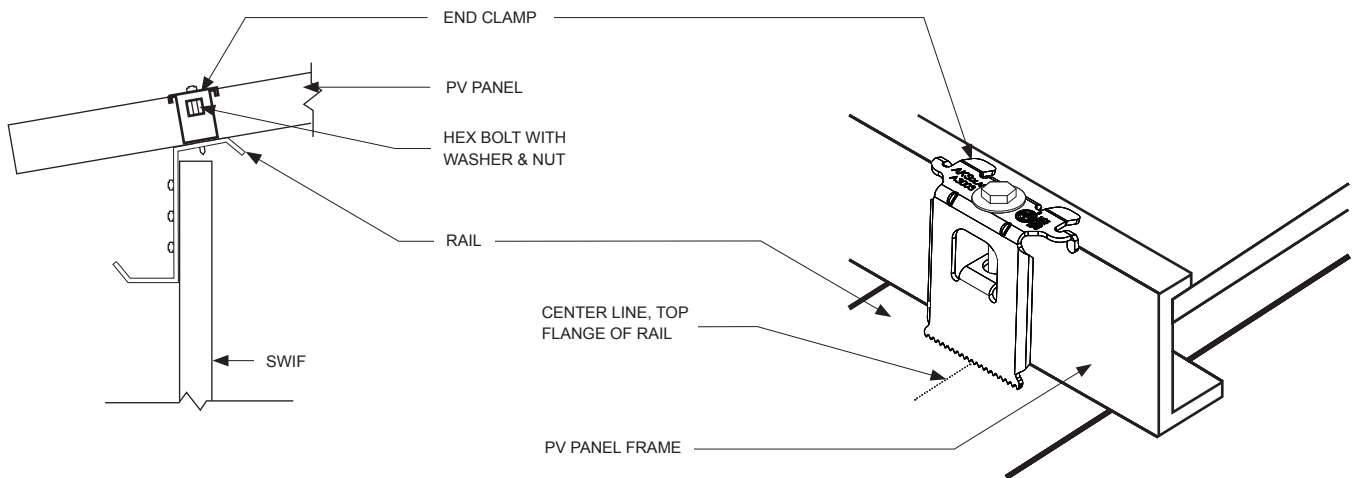
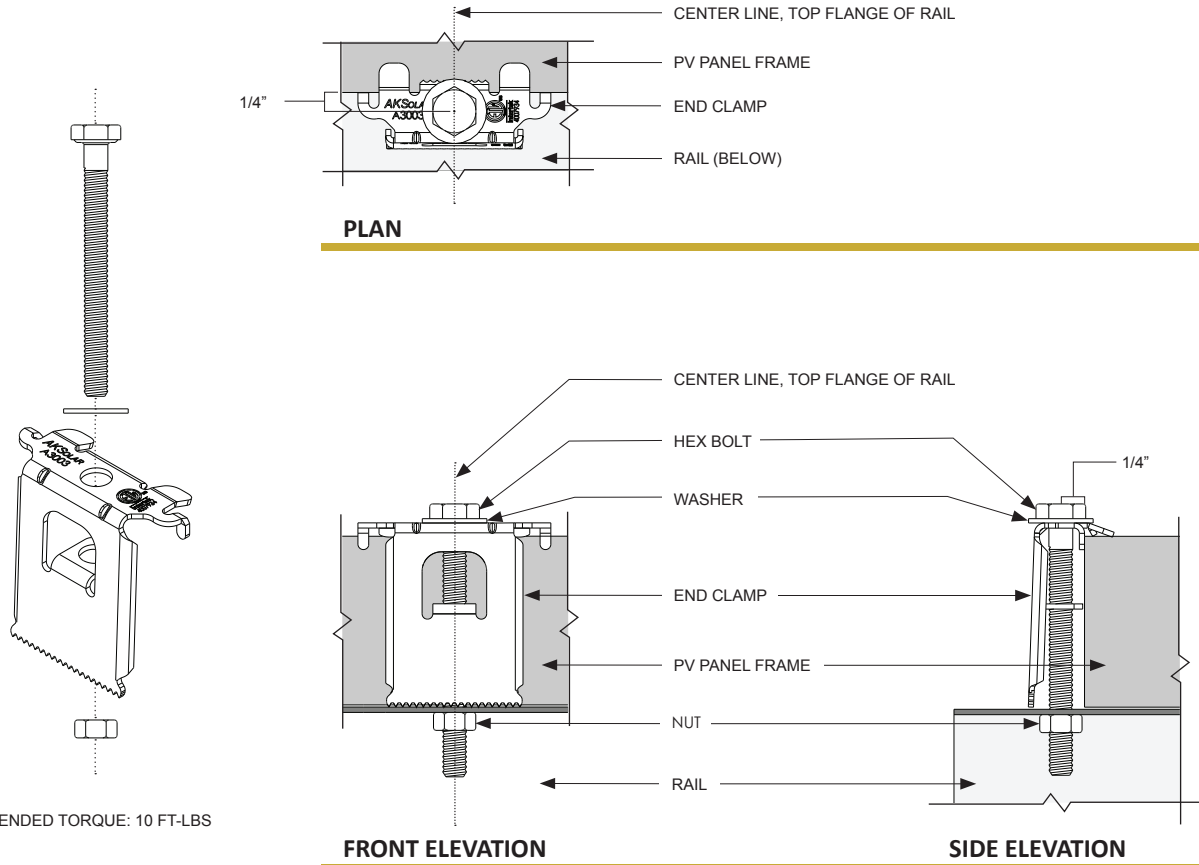

INSTALLATION SEQUENCE

SINGLE PANEL ARRAY

TWO PANEL SHARED RAIL ARRAY

1. LAYOUT AND FASTEN SWIFS TO ROOF STRUCTURE

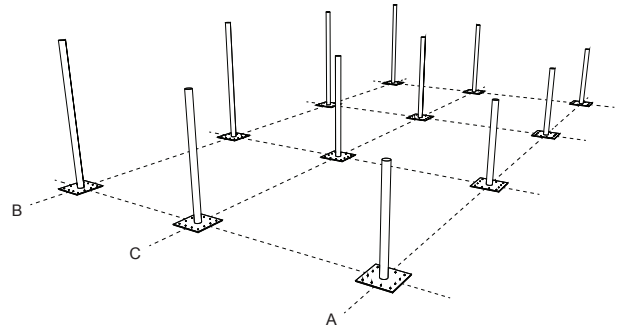
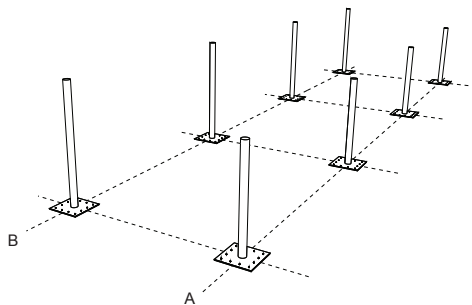

- Locate the SWIFS on the roof.
- Access the Roof Structure and secure the SWIFS with the appropriate fasteners.
- Ensure SWIFS are square and plumb.

2. LEVEL SWIFS

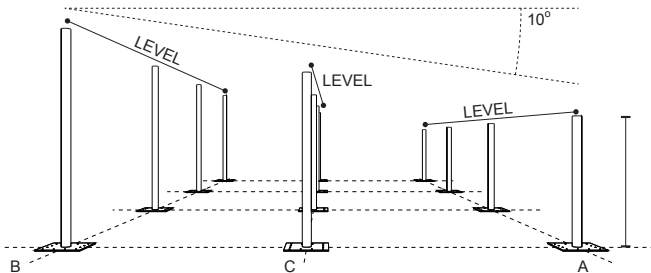
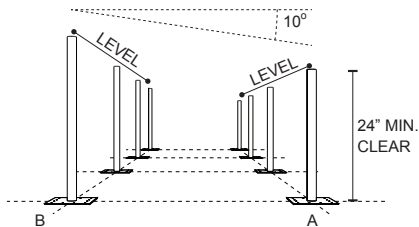

- Where required, trim the top of the SWIFS level across each row of the ARRAY.
- Where required, trim top of the SWIFS to achieve a 10 degree slope between RAILS.
- Apply a single coat of COLD GALVANIZED PAINT uniformly on any cut edges.

3. INSTALL FINISHED ROOF

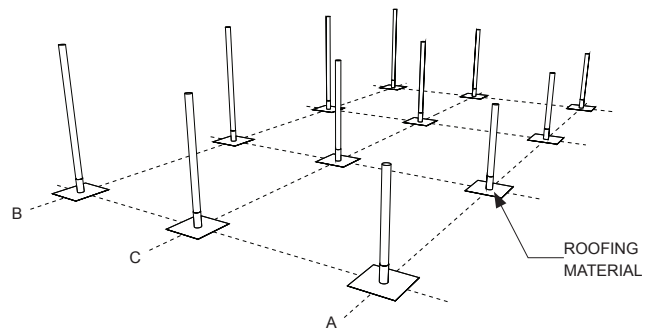
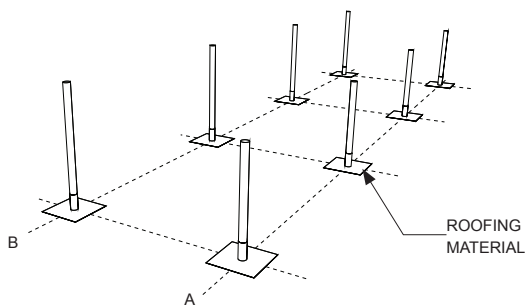

- Install the finished roof, encapsulating the SWIFS with the Roof Manufacturer's approved Pipe Penetration Detail.
- If installing on an existing roof, close the existing roof around the SWIFS with the Roof Manufacturer's approved Pipe Penetration Detail.

INSTALLATION SEQUENCE

SINGLE PANEL ARRAY

TWO PANEL SHARED RAIL ARRAY

4. ATTACH RAILS

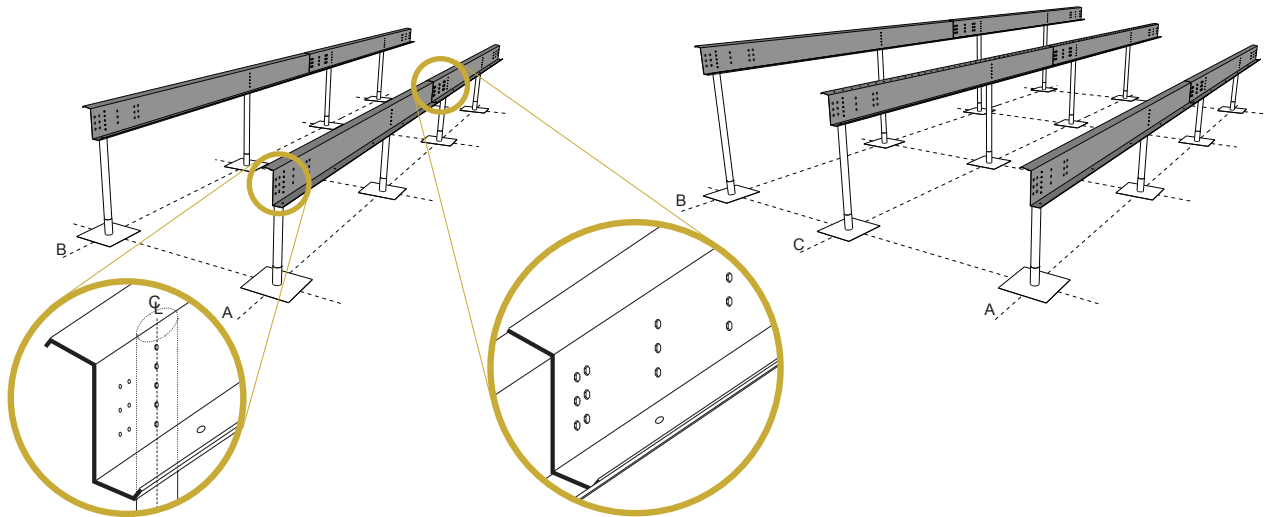

- Mount RAILS onto the SWIFS with SELF DRILLING BOLTS.
- Connect the RAILS with a RAIL SPLICE where required using the SPLICE BOLTS.

5. INSTALL PV PANELS

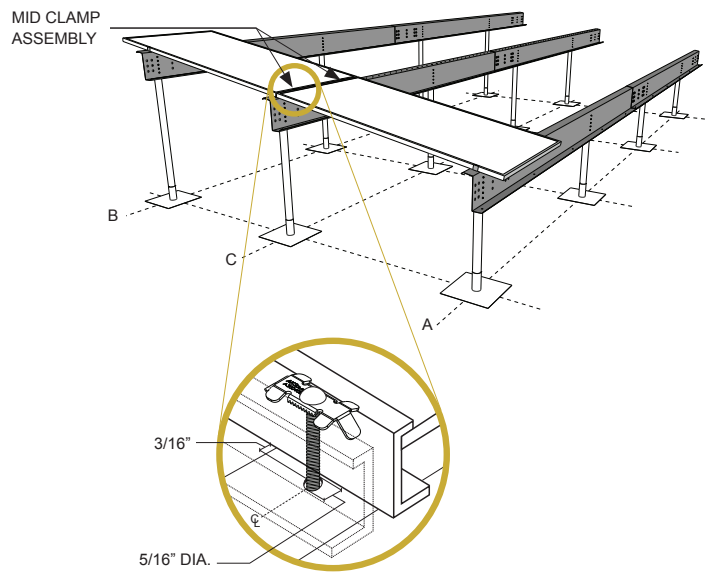
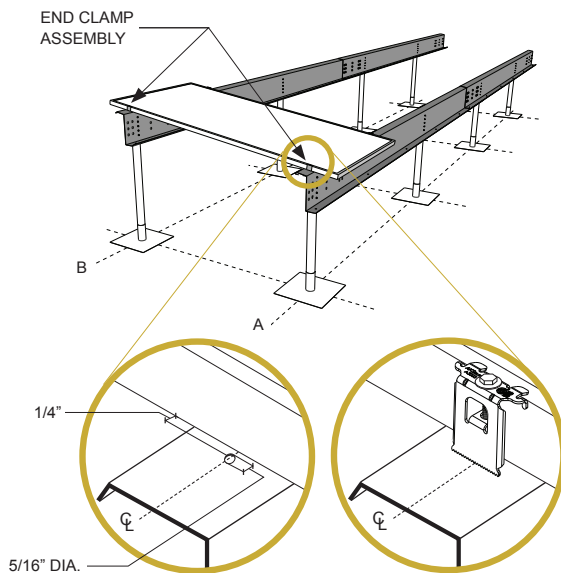

- Place the first PANEL on the RAILS.
- Place the first two PANELS on the RAILS.
- Square the PANELS with RAIL C.
- Use predrilled holes to install MID CLAMP ASSEMBLIES.
- Drill 5/16" holes at the center of the top flange of RAILS A + B, centered 1/4" from the edge of the PANEL frame.
- Attach the PANEL(S) to the RAILS with END CLAMP ASSEMBLIES.
- Drill 5/16" holes in RAILS A + B on the opposite sides of the PANEL(S) for to prepare for MID CLAMP ASSEMBLIES.

INSTALLATION SEQUENCE

SINGLE PANEL ARRAY

TWO PANEL SHARED RAIL ARRAY

6. INSTALL REMAINING PV PANELS

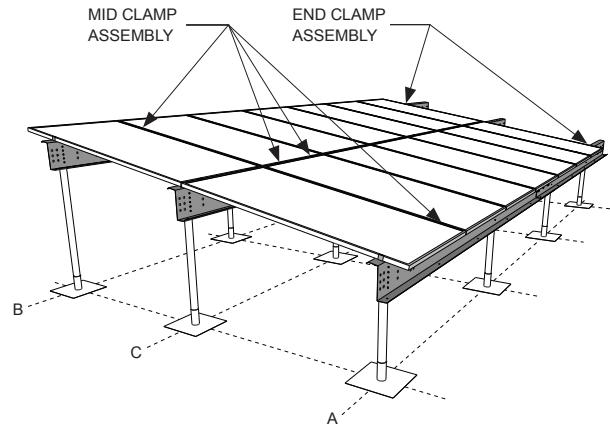
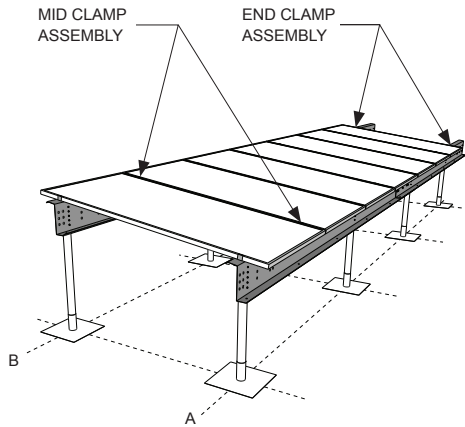

- Place the next PANEL on the RAILS.
 - Place the next two PANELS on the RAILS.
 - Square the PANELS with RAIL C.
 - Use predrilled holes to loosely install MID CLAMP ASSEMBLIES at RAIL C.
-
- Place MID CLAMP ASSEMBLIES between the PANELS at RAILS A + B.
 - Use a Rubber Mallet to snug the PANELS to all MID CLAMP ASSEMBLIES, then fully tighten them down.
 - Install remaining panels in the same fashion.
 - Terminate the Array by installing END CLAMP ASSEMBLIES on the PANELS at the far end of RAILS A + B.

BONDING CONNECTION GROUND PATHS



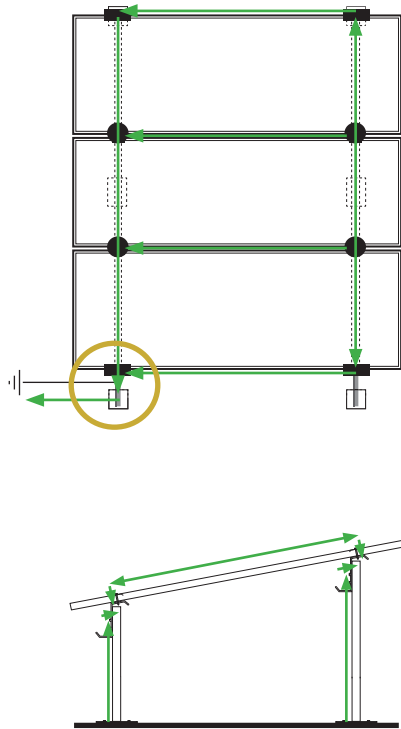

SINGLE PANEL ARRAY

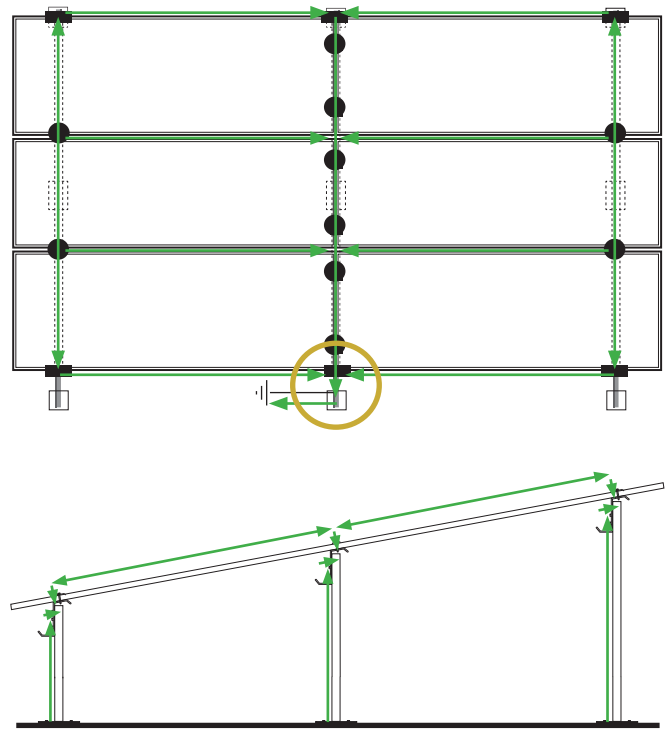

TWO PANEL SHARED RAIL ARRAY



KEY

GROUNDING PATH	
BONDED END CLAMP	
BONDED MID CLAMP	
BONDED RAIL SPLICE	
GROUNDING LUG AND BARE #6 STRANDED COPPER GROUND WIRE	

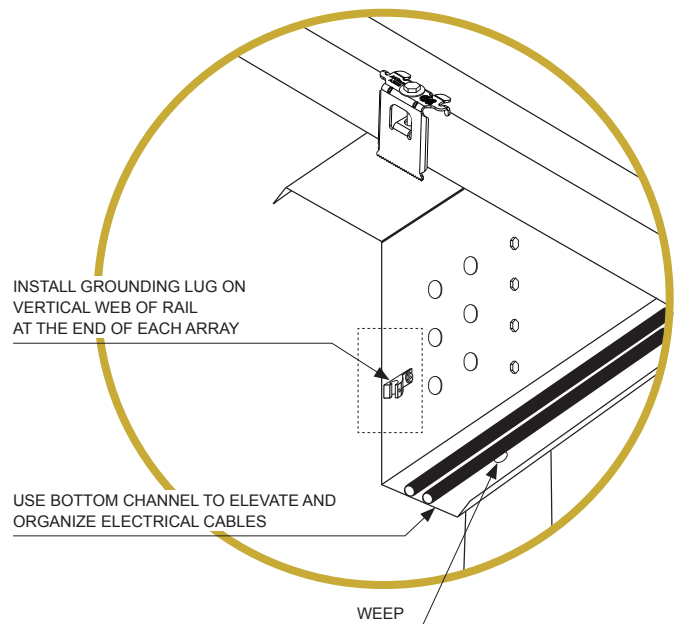

PANEL COMPATIBILITY

UL 2703 LIST OF APPROVED MODULES

Refer to the SWIF *TEN* Racking APPROVED PV MODULES LIST available for download on the website at www.SWIFRACK.com/downloads.

- All modules listed have been certified for Bonding & Grounding when used with SWIF *TEN* Solar Racking.
- Module Types 1, 2, 16, 29, and 30 have demonstrated a System Fire Class Rating of Class A with UL 61730-2.
- Refer to the PV module manufacturer's Installation Manual for approved clamp configurations.

*PV Module options continue to grow and improve every day. Call SWIF Rack at (541) 490-0536 or email us at www.SWIFRACK.com/ContactUs if the PV Module you want to use for your project is not included in this list yet, if the clamp mounting configuration you require isn't approved by the PV Module Manufacturer yet or if the PV Module is not yet evaluated for a Fire Rating. SWIF Rack will evaluate the panel for use with our system and work with the Module Manufacturer and an UL evaluating entity to certify the PV Module with the SWIF **TEN** Racking System.*

MARKINGS

PLACEMENT OF MARKING

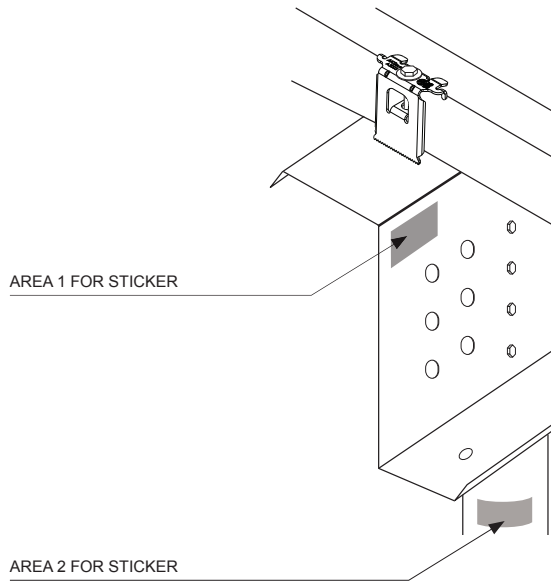

- Product markings are located on a UL 969 compliant sticker applied either to the RAILS or to SWIF A as shown.



- “YYYY” denotes the year of manufacture.
- “WW” denotes the week of manufacture of 52 weeks in a year.